

---

# Overview of Privacy Management in Ubiquitous Computing Environments

Shigeki Yamada

E-mail: [shigeki@nii.ac.jp](mailto:shigeki@nii.ac.jp)

National Institute of Informatics (NII)

October 3, 2003

# Why is Privacy Management NII Important in Ubicomp Environments?

---

- Two major concepts of ubiquitous computing
  - Ubiquity
  - Invisibility
    - Invisibility requires context-awareness that captures and interprets user context
    - User context includes privacy-sensitive personal data such as user's location, activity status, and preferences
- New privacy protection technologies are required for ubiquitous environments
  - Dynamic changes of user's computing and communication environments

# Privacy Invasions in Ubicomp Environments

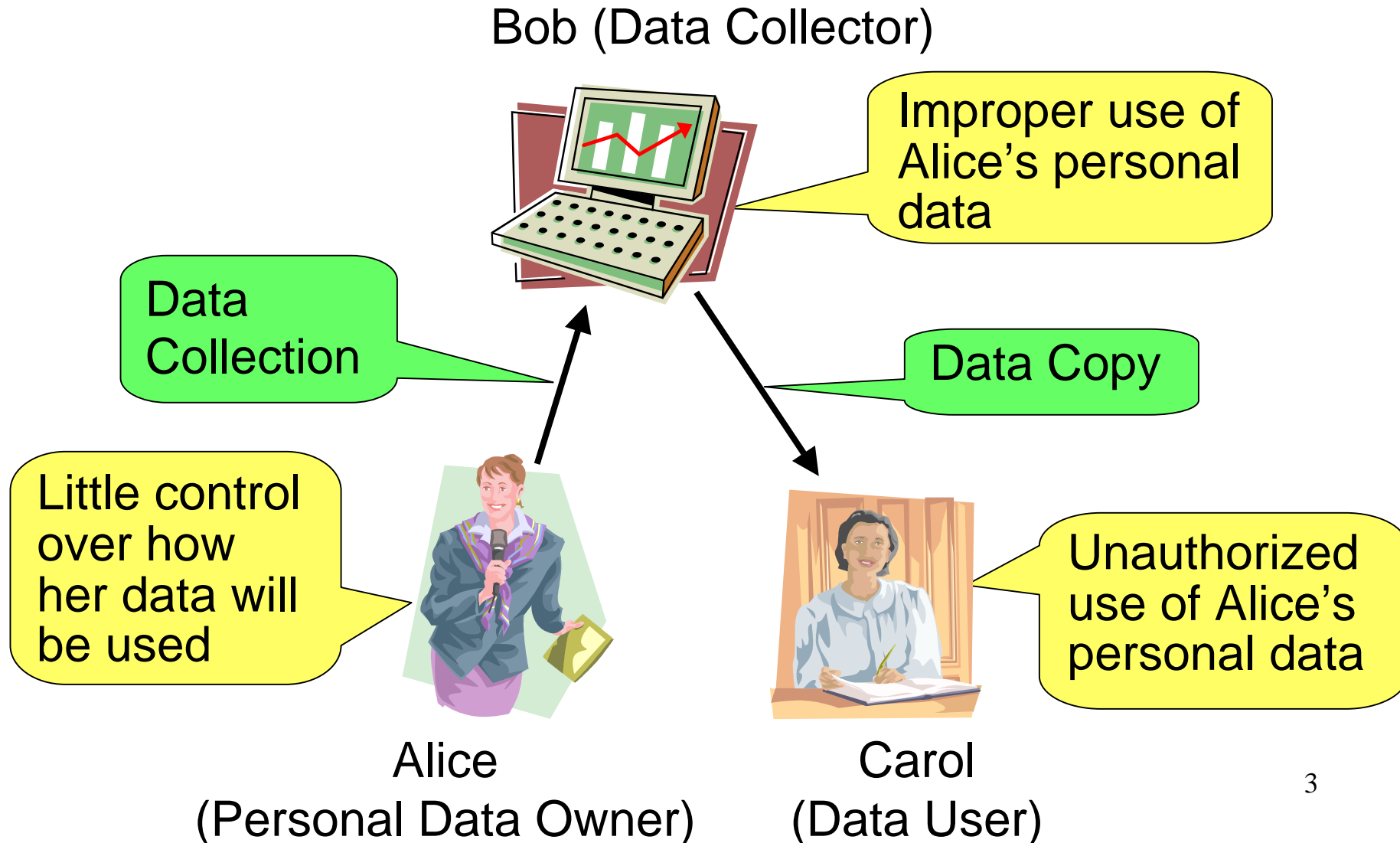

# Privacy Management Issues

---

- Where to store personal data?
  - End-User Centric Architecture (ECA)
    - Into stationary servers and devices
    - Into wearable servers and devices
  - Network- Centric Architecture (NCA)
- Who manages privacy?
  - User, Network Operator, or Service Provider
- How to protect privacy?
  - Principle of Minimum Asymmetry
  - P3P and pawS system
  - Other technologies

# Context Data Storage Management : ECA

NII

## (End-User Centric Architecture)

- User context data are stored in user facilities and managed by users or service providers
- Users feel easy
- User has all the responsibility

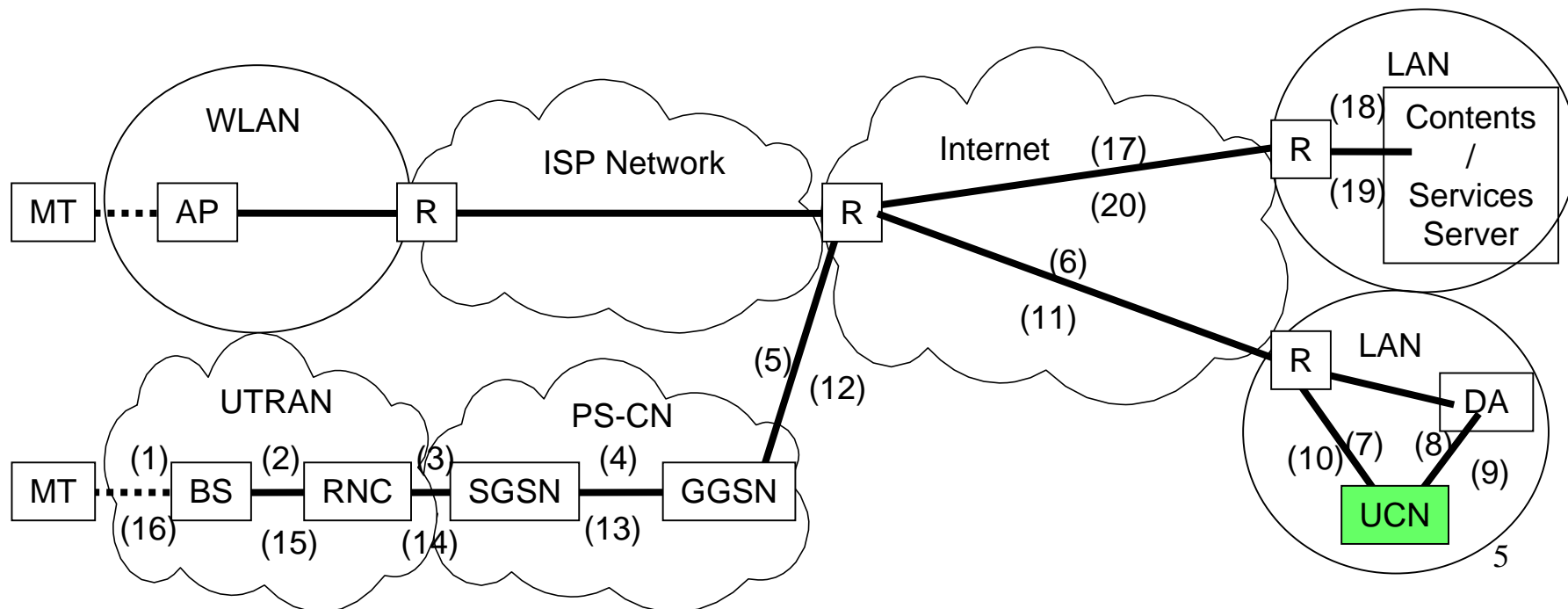

# Context Data Storage Management : NCA

NII

## (Network Centric Architecture)

- User context data are stored inside the 3GPP All IP Network managed by Network Operators
- Secure and uniform management
- Users may feel uneasy

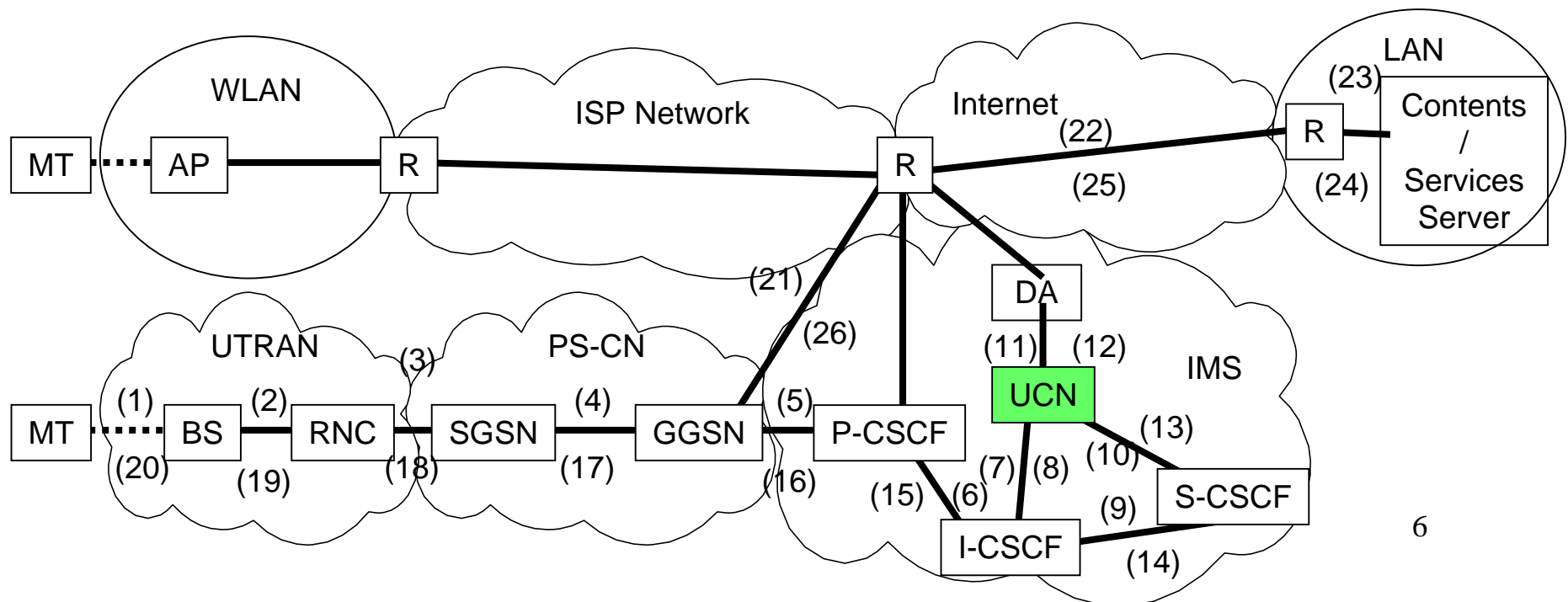

# Design Space for Privacy Protection

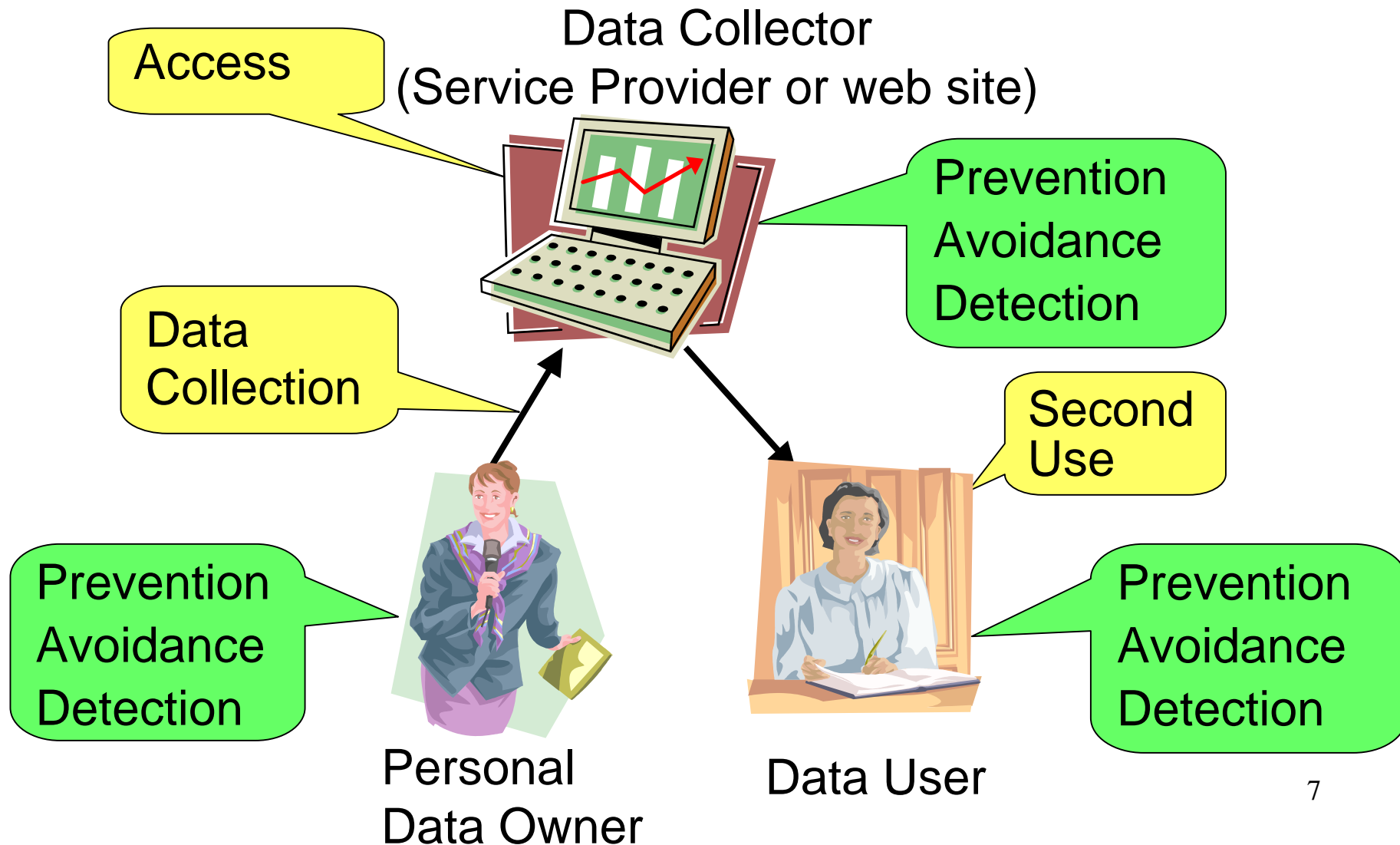

# Classification of Privacy Protection Technologies (by X. Jiang (UCB))<sup>NII</sup>

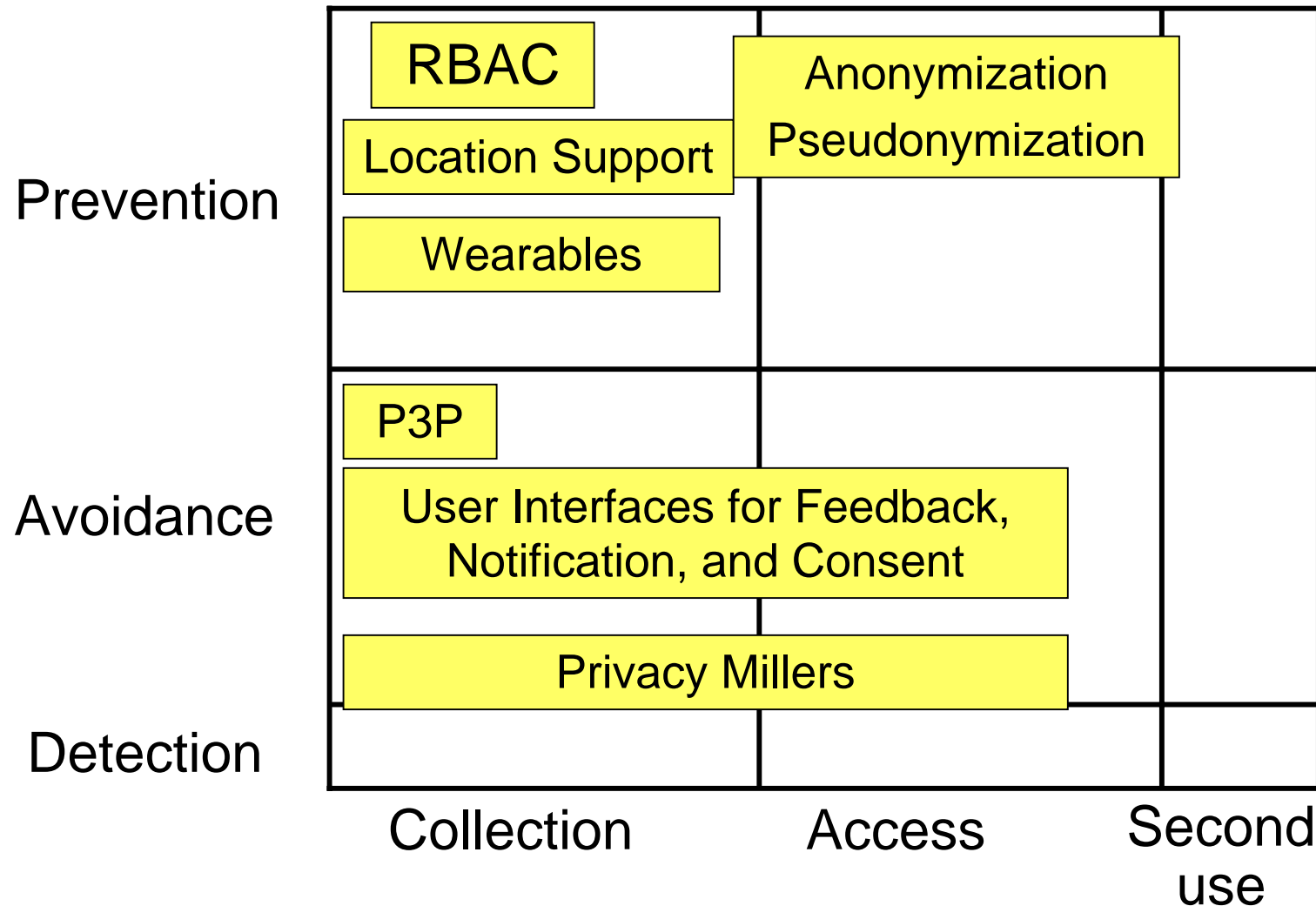

# Principle of Minimum Asymmetry

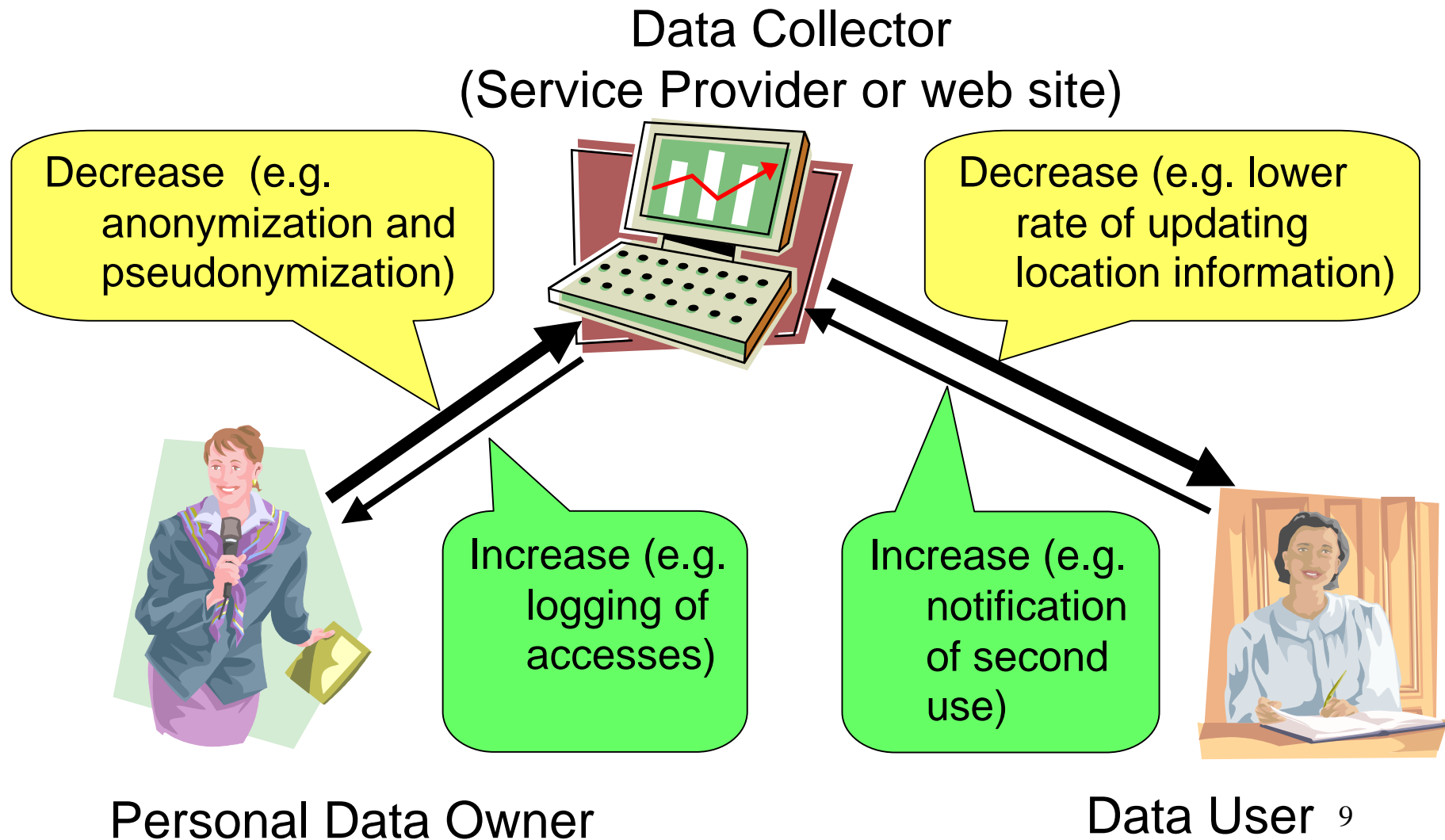

# Platform for Privacy Preferences NII Project (P3P)

---

- Developed by World Wide Web Consortium (W3C)
- Web sites disclose their privacy policies in a standard XML format
- Web browsers automatically retrieve P3P privacy policies and compare them to privacy preferences of personal data owners

# P3P Protocol

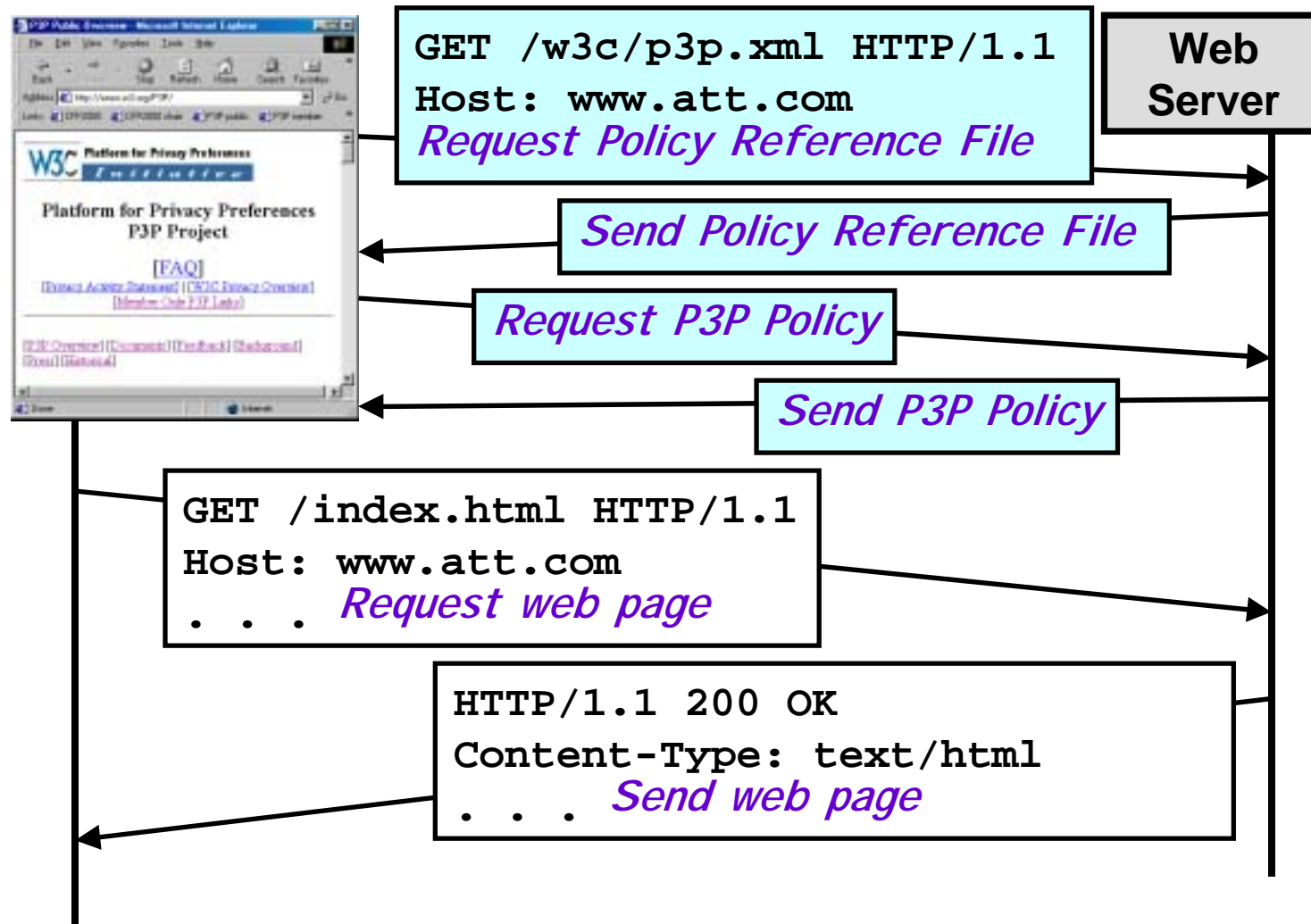

# pawS: a Privacy Protection System (ETH)

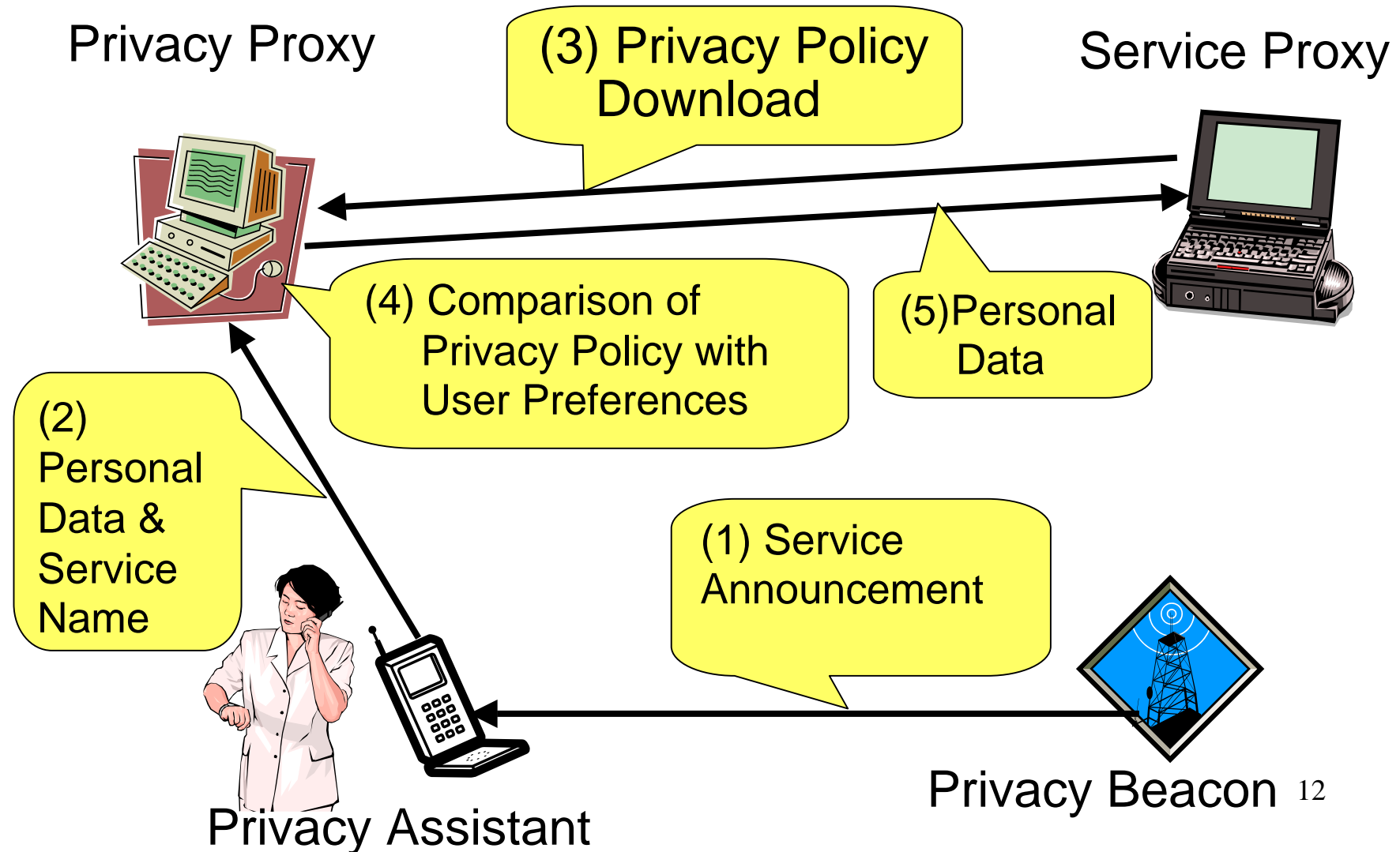

# Mobile Agent-based Privacy System for Controlling Second Use (NII)

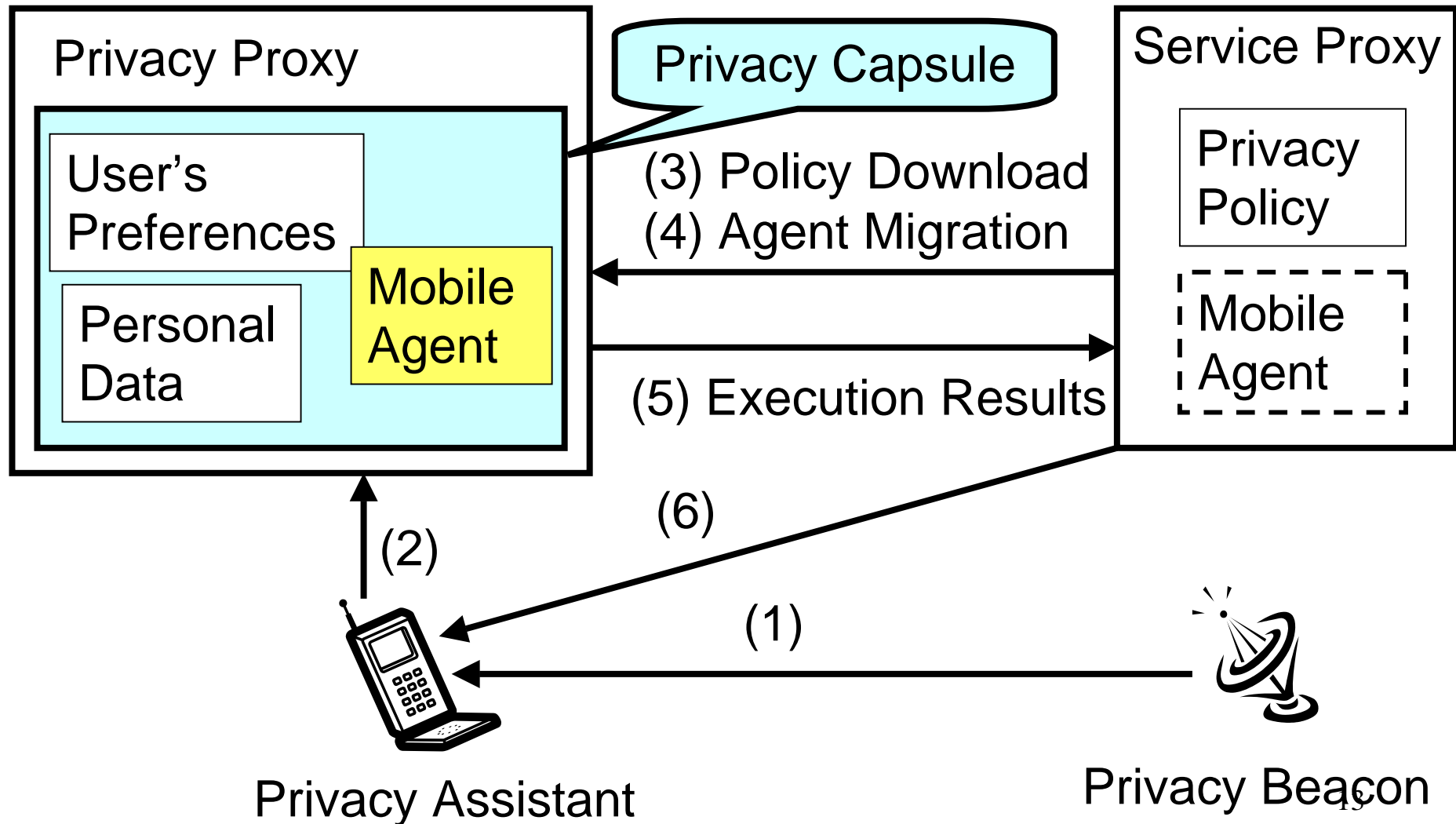

# Other Privacy Protection Technologies

---

- Location Support System: the Cricket system [MIT]
  - Allows client to learn their location without centralized tracking to construct location-specific queries
- Wearables
  - Use person's own workstations [Xerox PARC] or wearable computers [MIT] to store personal data
- Privacy Miller (Georgia Tech)
  - Shows end-users what information is being collected, and what information has been accessed and by whom.
  - Helps end-users avoid risky situations

# Concluding Remarks

---

- Privacy management will be increasingly important in ubiquitous computing networks
- Numerous privacy protection and management technologies have been emerging
- No simple solution but integration of various technologies for managing privacy
- Non-technical aspects must also be considered